

# Montageanleitung DORMA AGILE 150 DORMOTION Wandmontage

## Installation instruction DORMA AGILE 150 DORMOTION Installation to wall

### Inhaltsverzeichnis: Index of contents:

S. 2-3	Wichtige Informationen / Important information
S. 3	Benötigte Werkzeuge / requisite tools
S. 4	Glasbearbeitung DORMOTION L / glass preparation DORMOTION L
S. 4	Lieferumfang DORMOTION L / scope of delivery DORMOTION L
S. 5	Glasbearbeitung DORMOTION XL / glass preparation DORMOTION XL
S. 5	Lieferumfang DORMOTION XL / scope of delivery DORMOTION XL
S. 6	Position der Laufschiene vor der Maueröffnung / position of track rail ahead the wall opening
S. 7	1. Montage des Winkelprofils / installation of the angle profile
S. 8	2. Montage der Bodenführung / installation of the floor guide
S. 9	3. Montage der Klemmwagen / installation of the clamping carrier
S. 10	4. Vorbereitung Aushebeschutz / preparation of anti-jump device
S. 10	5. Endmontage der Bodenführung / final installation of floor guide
S. 11	6. Montage der Dämpfereinheit / installation of the spring damper unit
S. 12/13	7. Montage der Schiebetür und Befestigung der Laufschiene 7. Fitting of sliding door and fixing of the track profile
S. 14	8. Höheneinstellung / height adjustment
S. 14	9. Einstellung des Aushebeschutzes / adjustment of the anti-jump device
S.15/16	10. Positionierung der Laufwegbegrenzer / positioning of panel stops
S. 17	11. Positionierung der DORMOTION Start / positioning of DORMOTION start
S. 18	12. Glaskantenschutz / glass edge protection
S. 19	13. Montage der Sichtschutzbürste (optional) / installation of brush profile (optional)
S. 20	14. Montage der Stirnabdeckungen / installation of end caps

**Wichtige Informationen:**  
**Important information:**

max. Flügelgewicht DORMOTION L: 80 kg  
 max. panel weight DORMOTION L: 80 kg

max. Höhe 3000 mm  
 max. height 3000 mm

max. Flügelgewicht DORMOTION XL: 150 kg  
 max. panel weight DORMOTION XL: 150 kg

Glasdicken: 8 - 13,5 mm  
 glass thicknesses: 8 - 13,5 mm

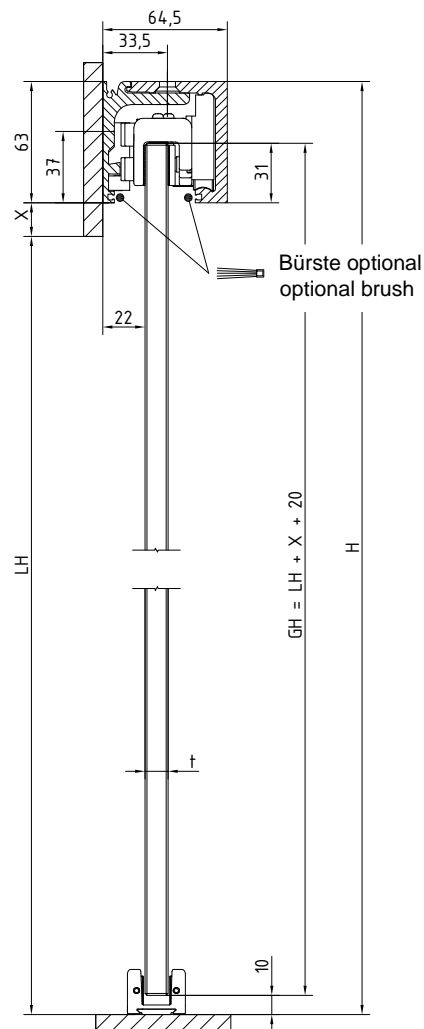
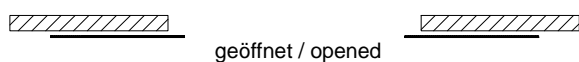
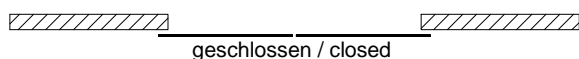
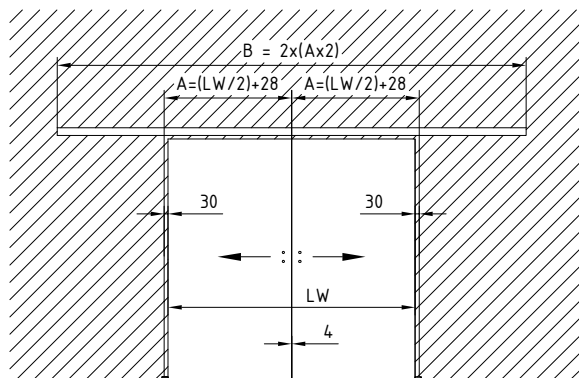
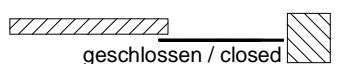
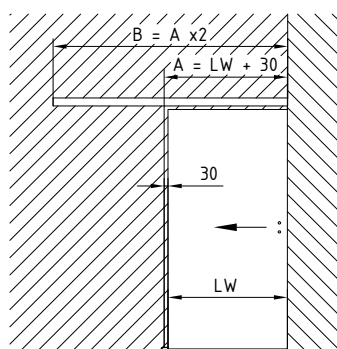
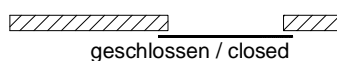
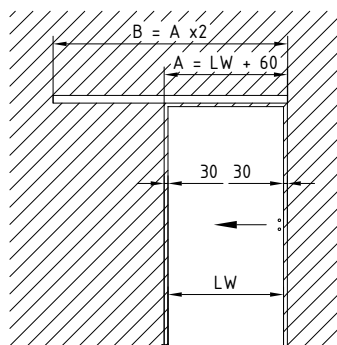

- A = Glasbreite / glass width
- B = Laufschiene(n)länge / length of track
- LW = Lichte Weite / clear opening width
- LH = Lichte Höhe / clear height
- H = Gesamthöhe / total height
- GH = Glashöhe / glass height
- t = Glasdicke / glass thickness

① = Bauteil/Baugruppe  
 Components

1.; 1.1; ... = Montagefolge  
 Mounting sequence

**Wichtige Informationen:**  
**Important information:**

Gläser mit selbstreinigenden Beschichtungen sind für AGILE 150 nicht geeignet - es sei denn, die Beschichtung wurde im Bereich der Klemmflächen (20mm Streifen an oberer Glaskante) ausgespart.

Vor der Montage Glasflächen im Bereich der Klemmflächen reinigen. Bitte nur Glasreiniger verwenden, die frei von Silikonen und Ölen sind (z.B. Aceton).

Voraussetzung für die Montage der Laufschiene ist eine ausgerichtete und tragfähige Unterkonstruktion bzw. Wand mit einer max. Toleranz von 2mm pro Meter.

Bei sachgerechter Bedienung der Anlage und normaler Frequentierung (20 Betätigungen pro Tag) ist ein wartungsfreier Betrieb über einen Nutzungszeitraum von min. 5 Jahren gegeben.

Bei höherer Frequentierung empfehlen wir einen jährlichen Wartungsvertrag zwischen Montagebetrieb und Endbenutzer.

Glass panels self-cleaning coatings are unsuitable for AGILE 150 - unless the clamping area (20mm band at the upper glass edge) is left coated.

All glass clamping areas are to be cleaned prior to installation. Only use glass cleaning products, free from silicones and oil (e.g. acetone).

Precondition for installation of trak is an aligned substructure or wall with a max. tolerance of 2mm per metre.

A maintenance free period of min. 5 years is given with an appropriate handling and normal frequency of approx. 20 cycles per day.

For higher frequency we recommend a maintenance contract between fitter and user for a yearly inspection.

**Benötigte Werkzeuge:**  
**Requisite tools:**

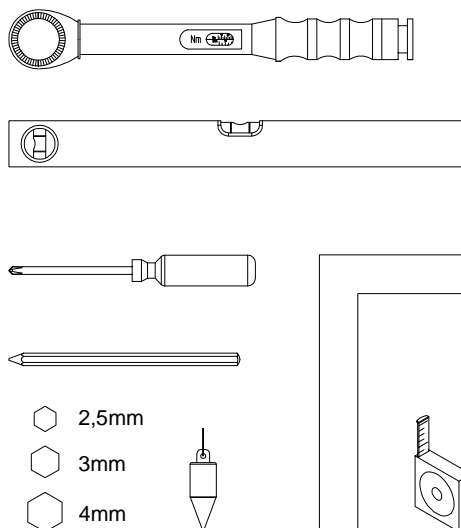
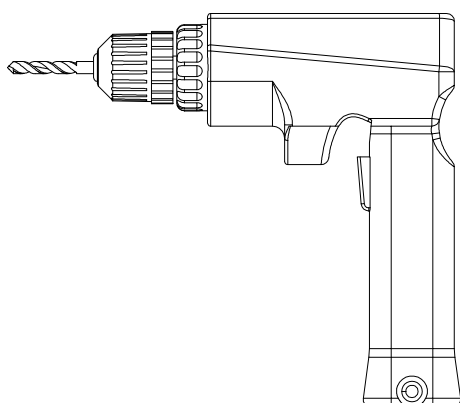

**Glasbearbeitung DORMOTION L:**  
**Glass preparation DORMOTION L:**

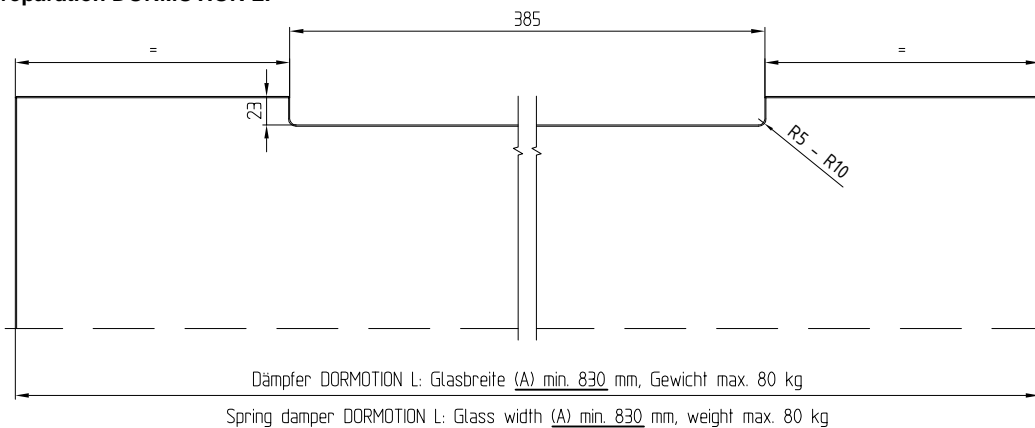

**Lieferumfang DORMOTION L:**  
**Scope of delivery DORMOTION L:**

- 1 . . . . . Winkelprofil / angle profile
- 2 . . . . . Laufschiene / track profile
- 3 . . . . . Schrauben DIN 7991 M6x12 / screw DIN 7991 M6x12
- 4 . . . . . Klemmwagen / clamp carrier
- 5 . . . . . Laufwegbegrenzer / panel stop
- 6 . . . . . Dämpfer DORMOTION L / spring damper DORMOTION L
- 7 . . . . . Dormotion Start / dormotion start
- 8 . . . . . Bodenführung / floor guide
- 9 . . . . . Zubehörbeutel mit Befestigungsmaterial / accessories package with fixing material
- 10 . . . . . Stirnabdeckungen / end caps
- 11 . . . . . Glaskantenschutz / glass edge protection
- 12 . . . . . Sichtschutzbürste (optional) / brush profile (optional)

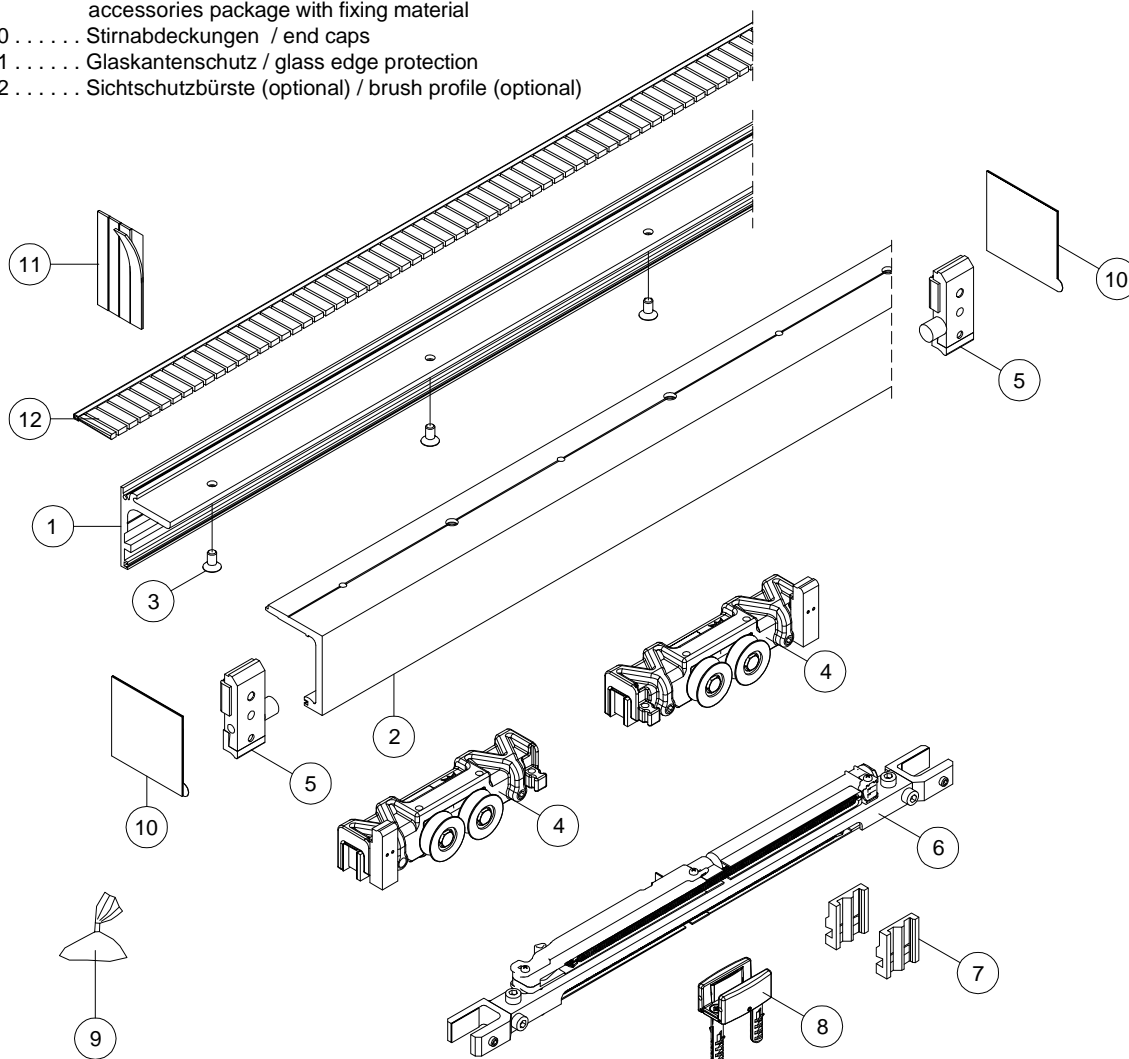

**Glasbearbeitung DORMOTION XL:**  
**Glass preparation DORMOTION XL:**

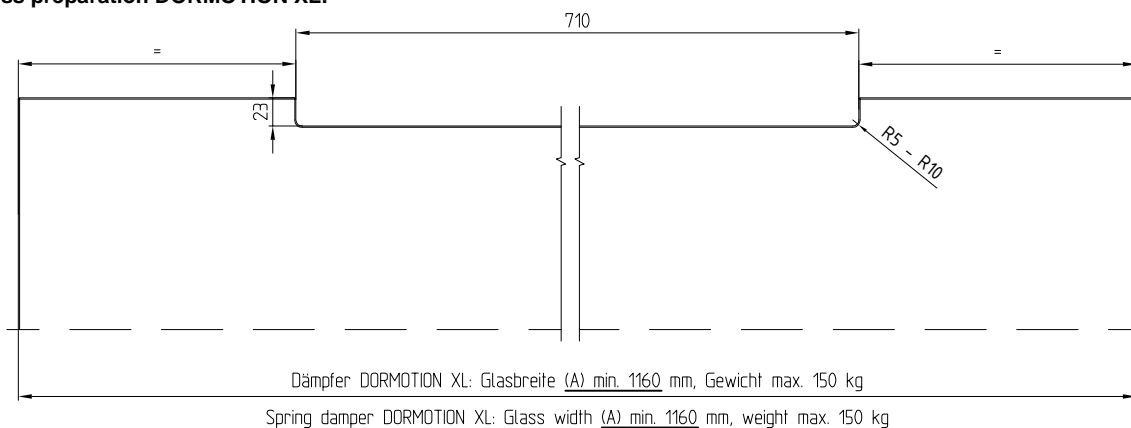

**Lieferumfang DORMOTION XL:**  
**Scope of delivery DORMOTION XL:**

- 1 . . . . . Winkelprofil / angle profile
- 2 . . . . . Laufschiene / track profile
- 3 . . . . . Schrauben DIN 7991 M6x12 / screw DIN 7991 M6x12
- 4 . . . . . Klemmwagen / clamp carrier
- 5 . . . . . Laufwegbegrenzer / panel stop
- 6 . . . . . Dämpfer DORMOTION XL / spring damper DORMOTION XL
- 7 . . . . . Dormotion Start / dormotion start
- 8 . . . . . Bodenführung / floor guide
- 9 . . . . . Zubehörbeutel mit Befestigungsmaterial / accessories package with fixing material
- 10 . . . . . Stirnabdeckungen / end caps
- 11 . . . . . Glaskantenschutz / glass edge protection
- 12 . . . . . Sichtschutzbürste (optional) / brush profile (optional)

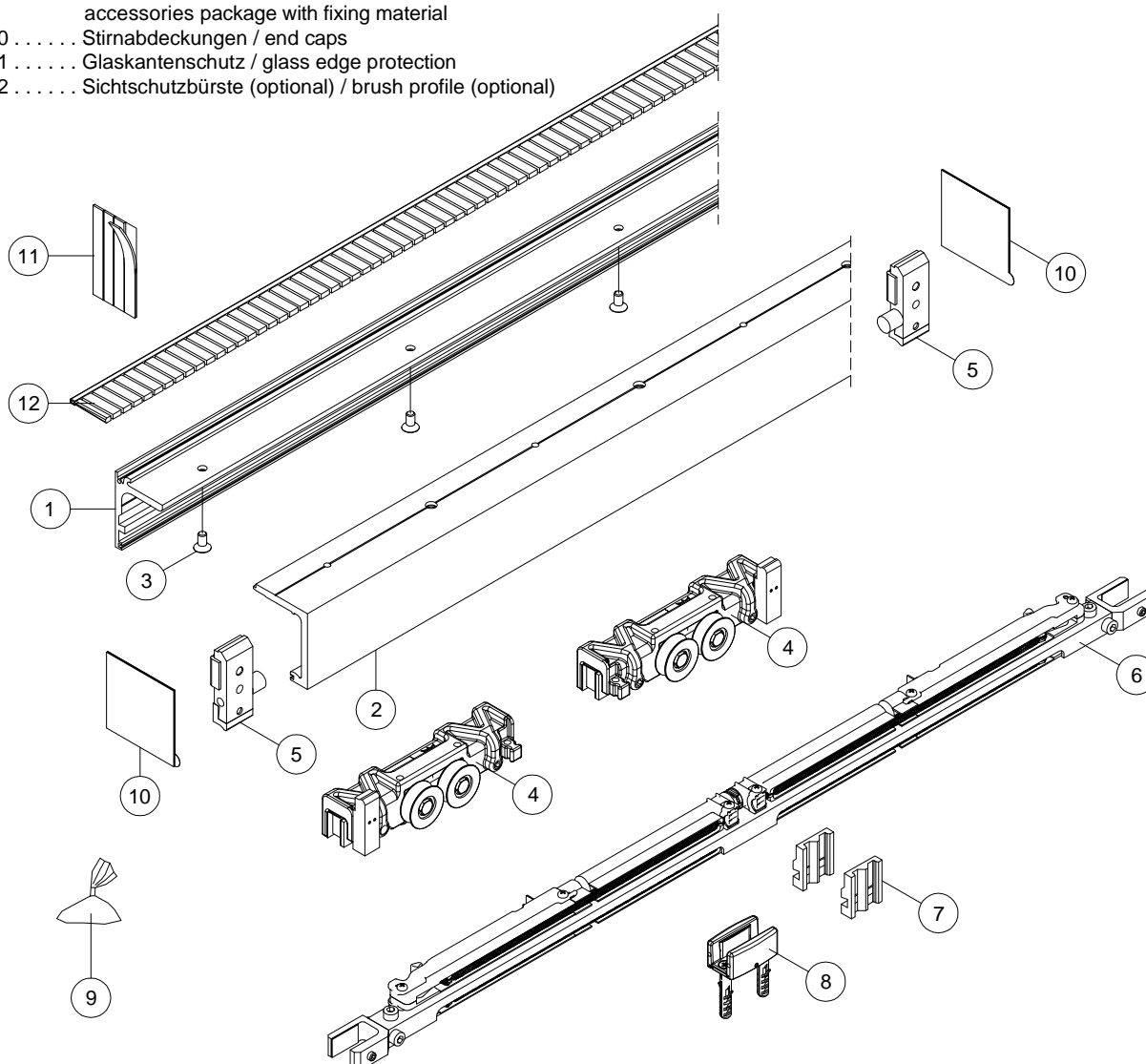

**Position der Laufschiene vor Maueröffnung:  
Position of track rail ahead the wall opening:**

Einzeltür / single door

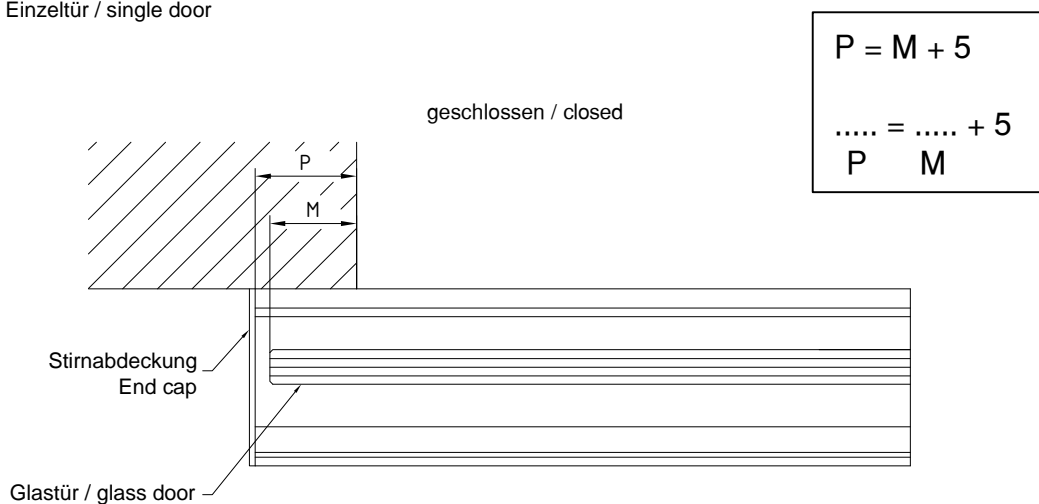

M= Glasüberstand (empfohlen 30mm)  
overlap of glass (recommend 30mm)  
P = Laufschieneüberstand / overlap of track profile

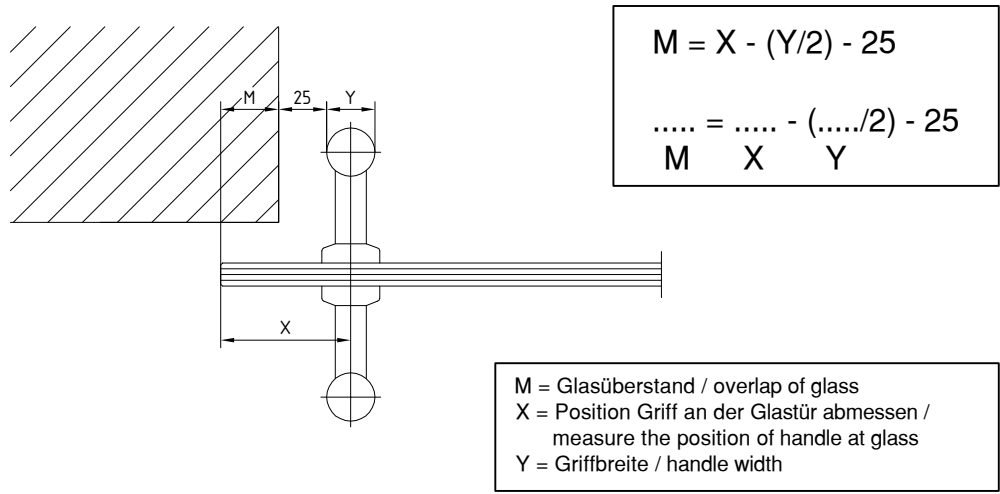

Der Glasüberstand (M) darf durch unterschiedliche Bedingungen wie z.B. Glasbohrung oder Griffdicke von dem empfohlenen Maß abweichen.



The glass overlap (M) can differ to the recommended measurements depending on position of drillings or handle thickness.

1. Montage des Winkelprofils:  
1. Installation of the angle profile:



Mitgelieferte Schrauben und Dübel sind nicht für jeden Untergrund geeignet.  
Geeignete auf den Untergrund abgestimmte Befestigungsmittel verwenden!

Delivered screws and plugs are not usable for all types of foundations!  
Please use suitable fixing materials according to foundation!

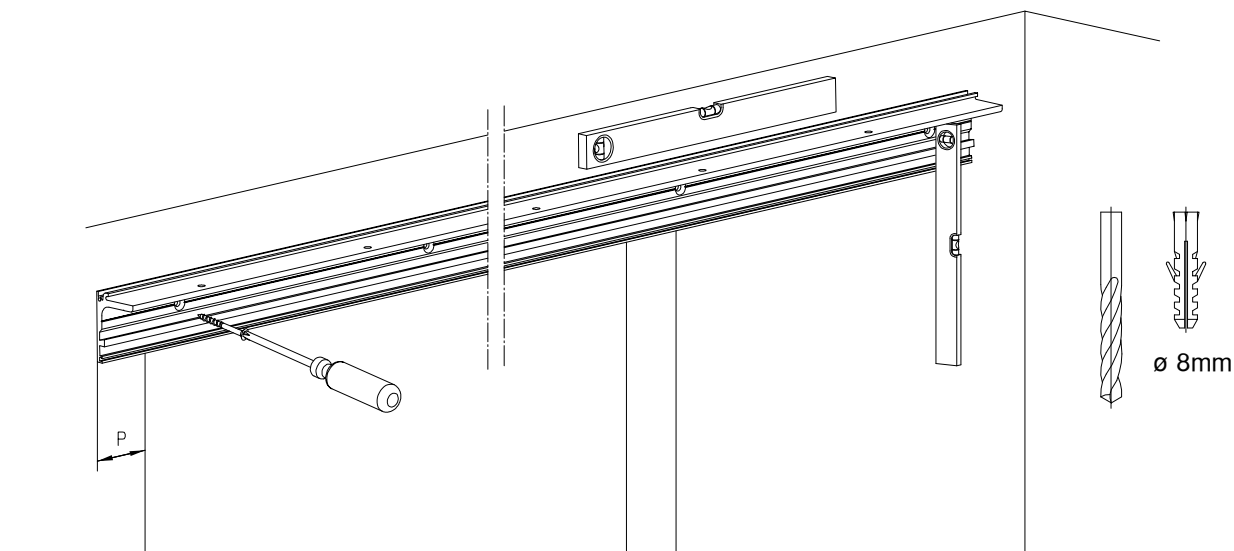

**2. Montage der Bodenführung:**  
**2. Installation of the floor guide:**



Geeignete auf den Untergrund abgestimmte Befestigungsmittel verwenden!  
 Please use suitable fixing material according to foundation!

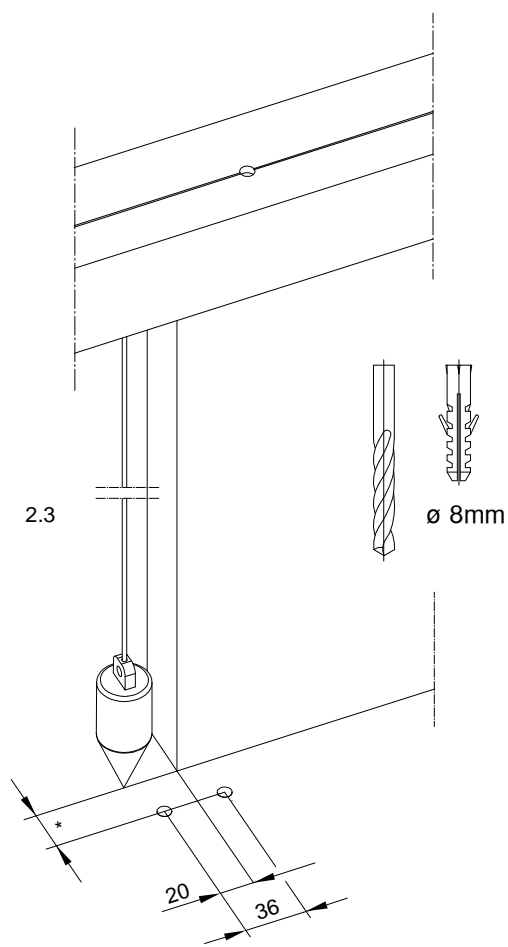
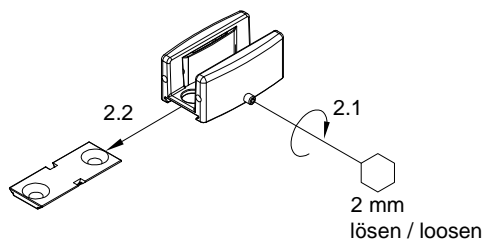

\* 22 + (Glasdicke / 2)  
 22 + (glass thickness / 2)

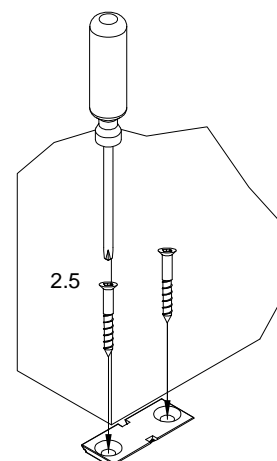
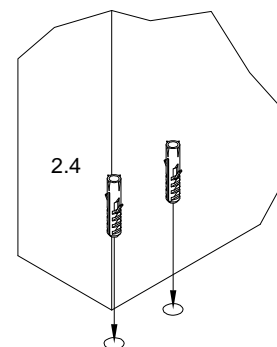



### 3. Montage der Klemmwagen: 3. Installation of clamp carriers:

#### Einzeltür / single door

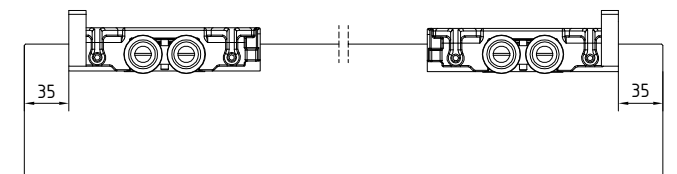

#### Doppeltür / double door



**Achtung:** Um einen bestmöglichen Glasschutz zu erreichen, empfehlen wir bei gegenläufigen Schiebetüren, die Verwendung des Abstandhalters Art. Nr.: 29.420.

**Attention:** For sliding doors moving in opposite directions, we recommend to use the spacer Art. No.: 29.420, to get the best possible glass protection.

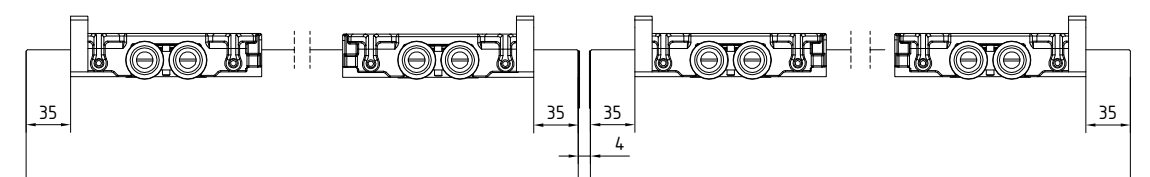

3.1 Vor der Montage Glasflächen im Bereich der Klemmflächen reinigen. Bitte nur Glasreiniger verwenden, die frei von Silikonen und Ölen sind (z.B. Aceton).

3.1 Before installation all glass clamping areas have to be cleaned first. Only use glass cleaning products, free from silicones and oil (e.g. acetone).

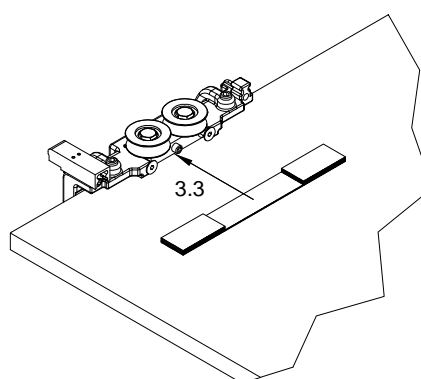
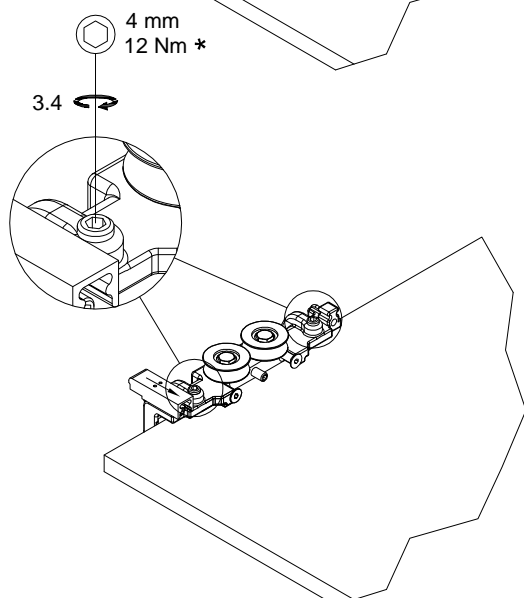
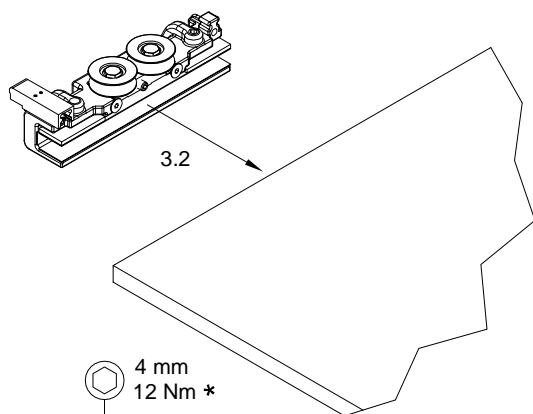

\* Alternativ:

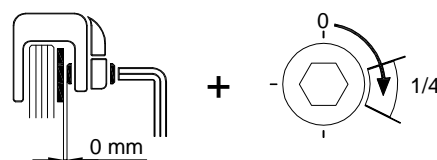

**4. Vorbereitung Aushebeschutz:**  
**4. Preparation of anti-jump device:**

4.1 Ist-Soll Vergleich durchführen.  
 4.1 Make a actual-theoretical comparison.

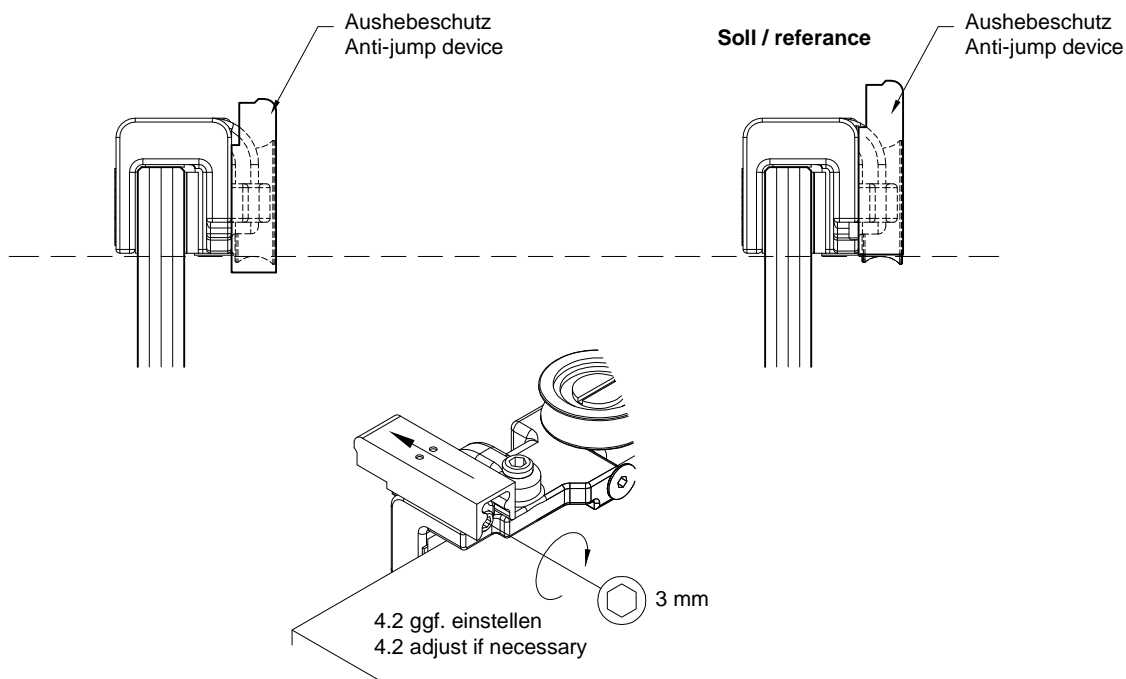

**5. Endmontage der Bodenführung:**  
**5. Final installation of floor guide:**

5.1 Tür vorsichtig öffnen.  
 5.1 Open the door carefully.

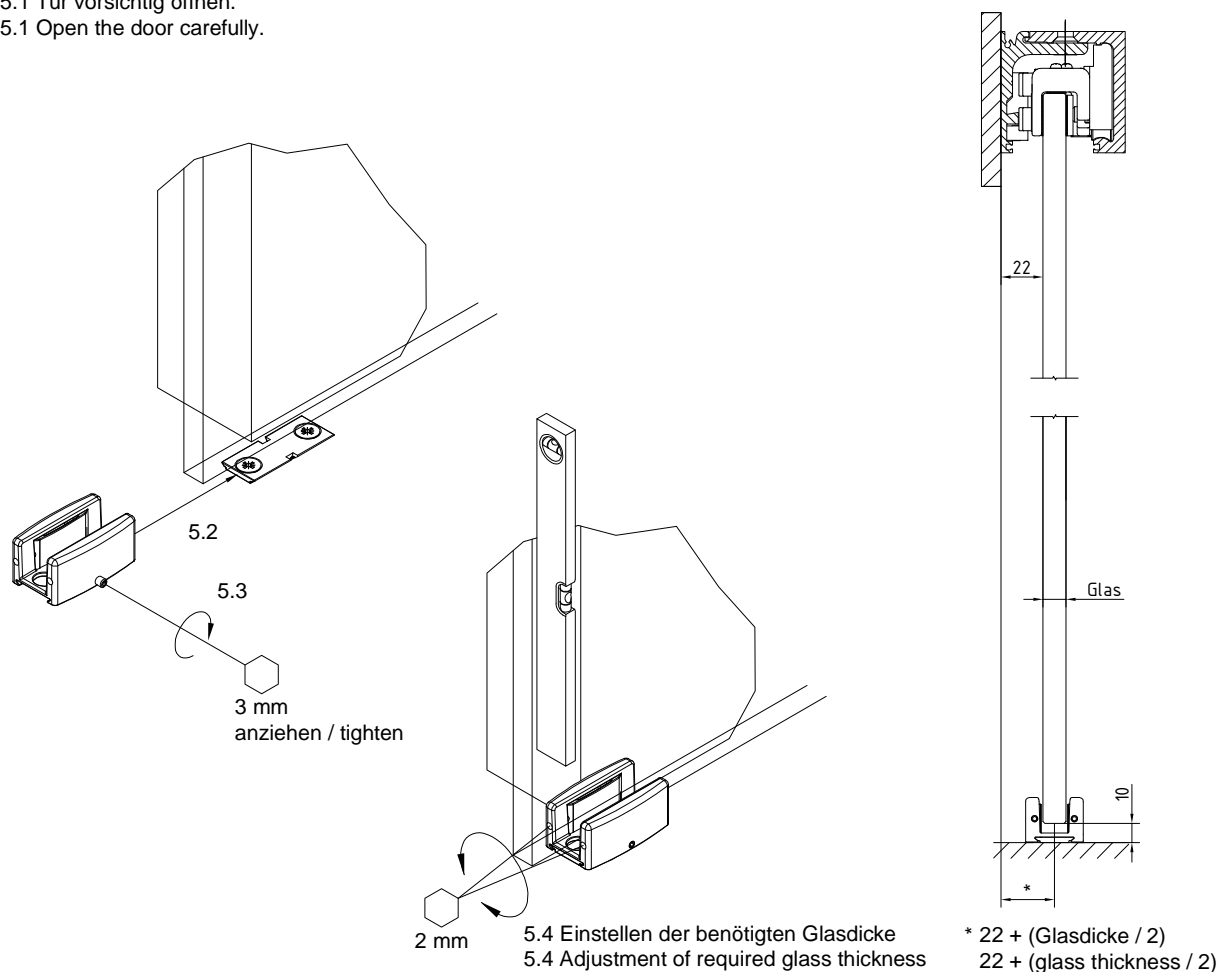

**6. Montage der Dämpfereinheit:  
6. Installation of spring damper unit:**



Bitte darauf achten, dass die Dämpfereinheit richtig herum montiert wird!  
Die Befestigungsschrauben müssen immer in Richtung der Laufrollen zeigen!

Please pay attention, to a correct installation of the spring damper unit.  
The connection screws always have to face towards the rollers.

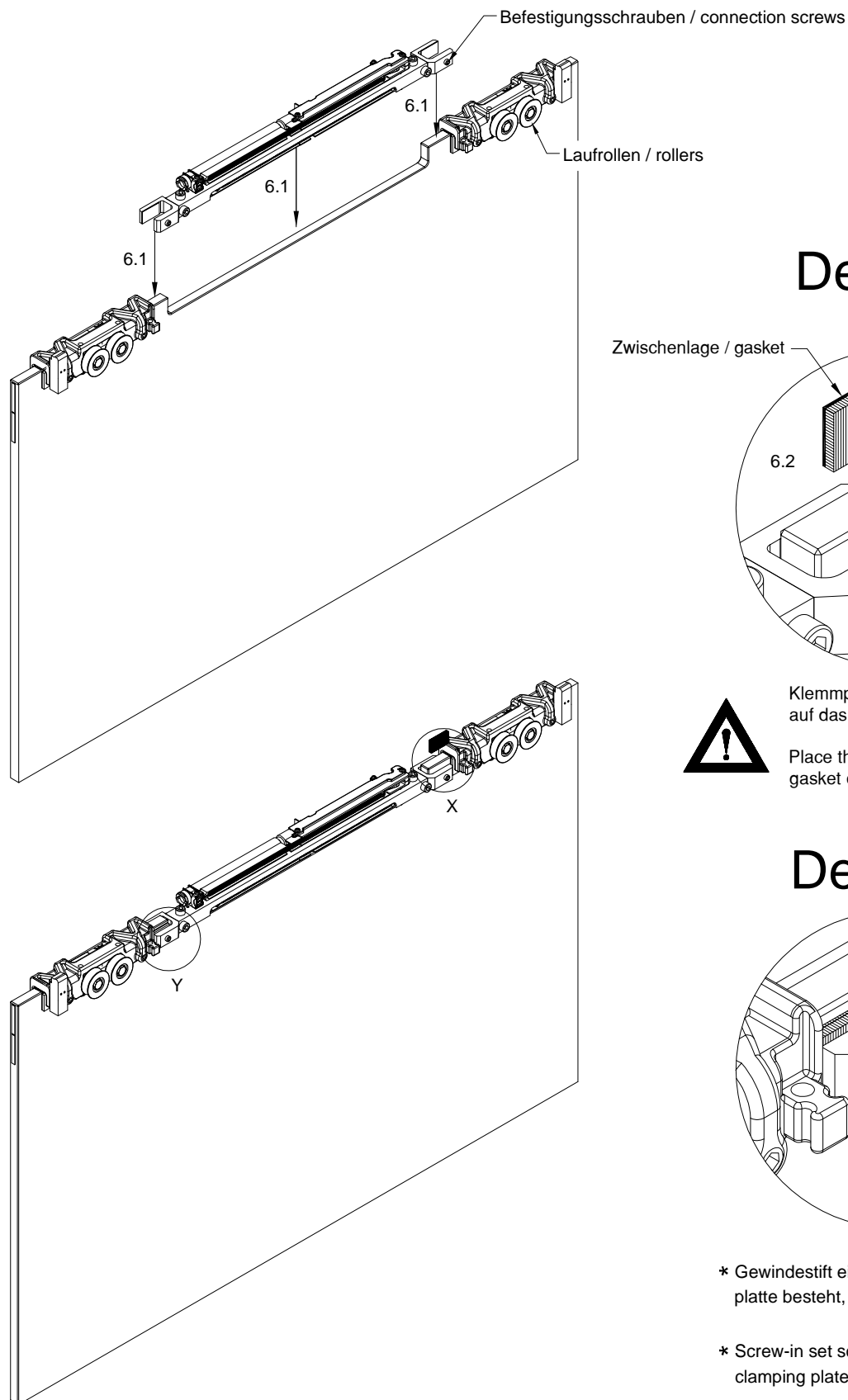

## Detail X

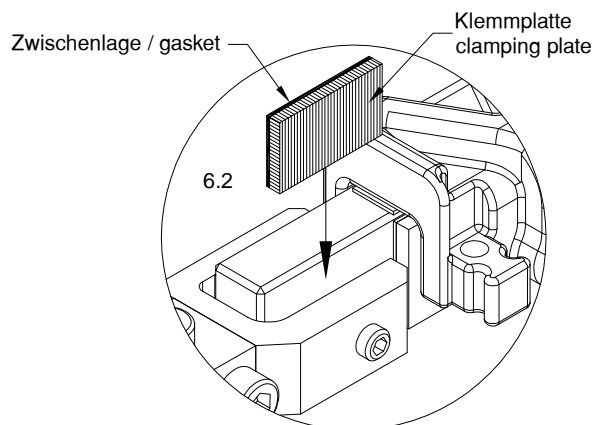

Klemmplatte mit der Zwischenlage auf das Glas legen.

Place the clamping plate with gasket onto glass.

## Detail Y

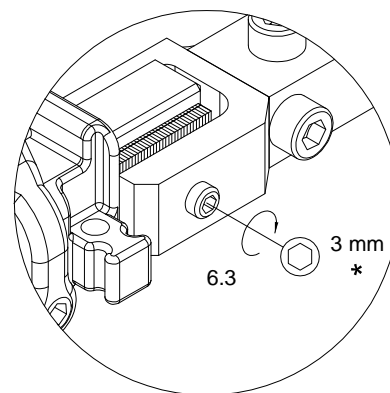

\* Gewindestift eindrehen bis Kontakt mit der Klemmplatte besteht, dann  $\frac{1}{2}$  Umdrehung anziehen.

\* Screw-in set screws until contact with clamping plate, then tighten  $\frac{1}{2}$  turn.

**7. Montage der Schiebetür und Befestigen der Laufschiene:**  
**7. Fitting of sliding door and fixing of the track profile:**

7.1 Zugfedern von beiden Dämpfereinheiten spannen.  
 7.1 Apply tension at the springs of both damper units.

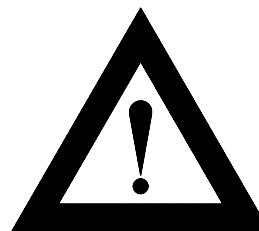

Schritt 7.1 bitte unbedingt beachten!  
 Insure that step 7.1 is followed!

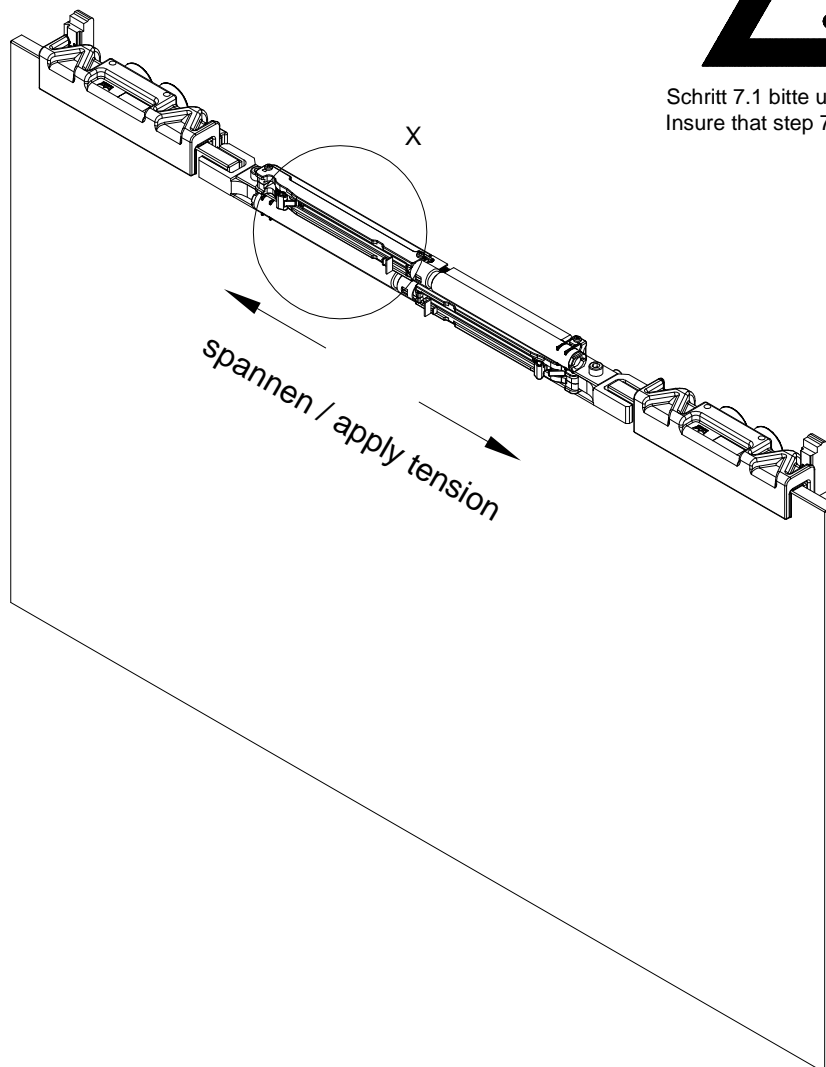

**DETAIL X**

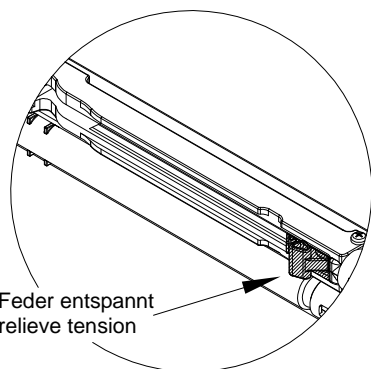

**DETAIL X**

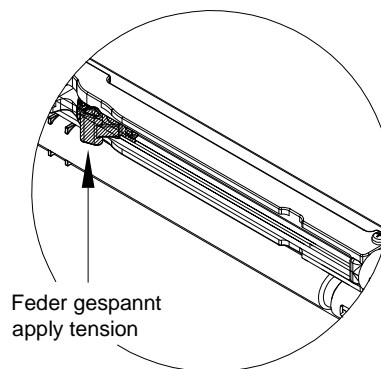

**7. Montage der Schiebetür und Befestigen der Laufschiene:**  
**7. Fitting of sliding door and fixing of the track profile:**

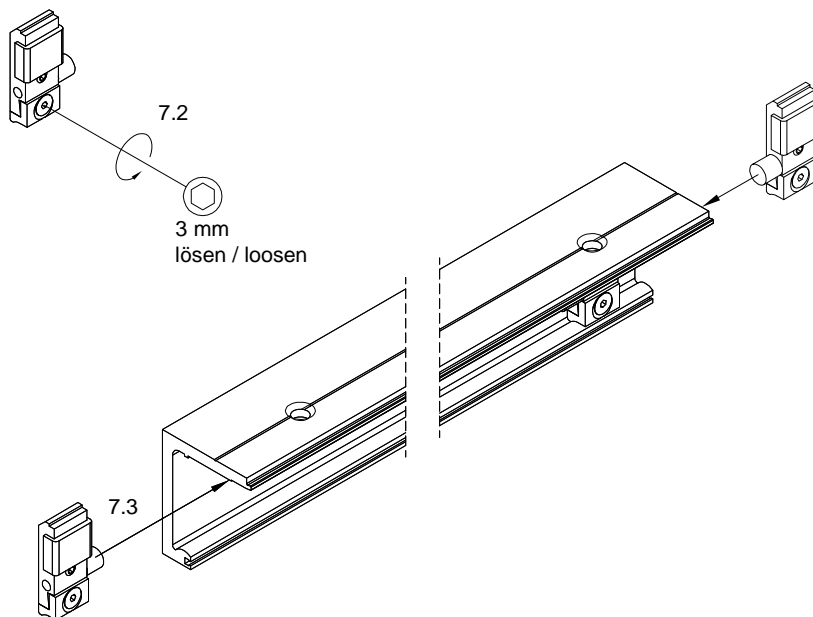

7.4 Scheibe auf Klötze stellen. Tür einschwenken und an das Winkelprofil lehnen!

7.4 Position glass onto blocks. Align the door and lean the door against the angle profile!

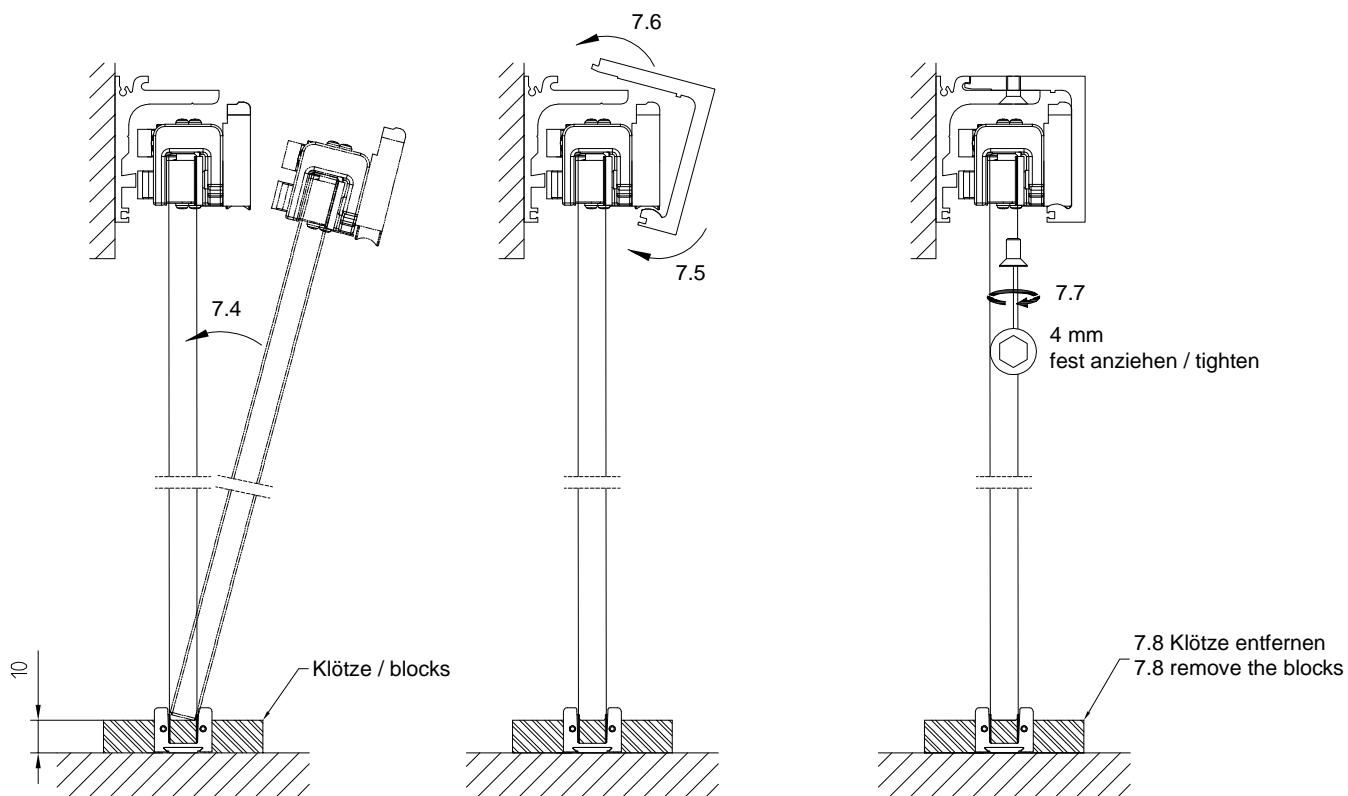

**8. Höheneinstellung:**  
**8. Height adjustment:**

Verstellmöglichkeit: ± 5mm  
 Adjustability: ± 5mm

**DETAIL Y**

Höheneinstellung der Klemmwagen  
 Height adjustment of clamp carrier

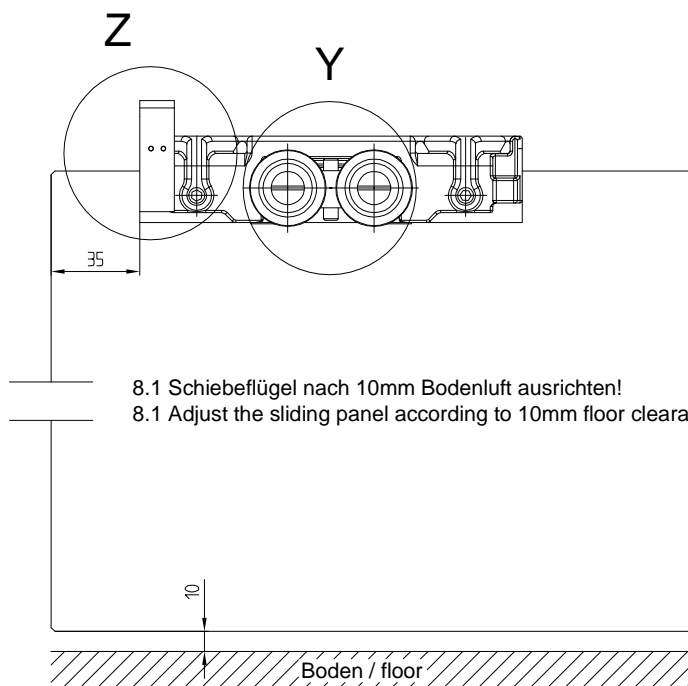

8.1 Schiebeflügel nach 10mm Bodenluft ausrichten!  
 8.1 Adjust the sliding panel according to 10mm floor clearance!

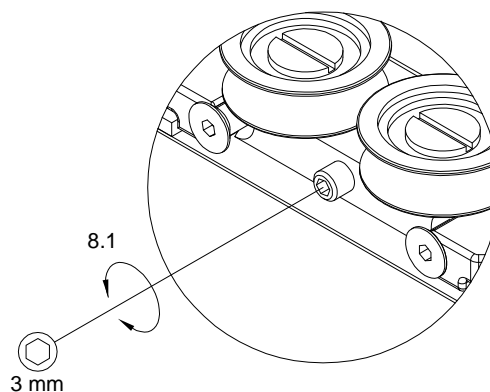

**DETAIL Y**

Festsetzung der Höheneinstellung  
 Fixing of height adjustment

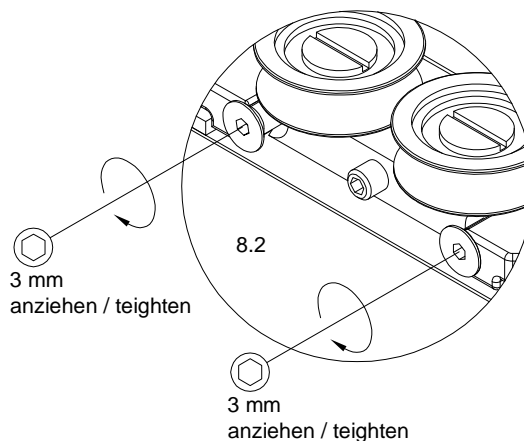

**9. Einstellung des Aushebeschutzes:**  
**9. Adjustment of the anti-jump device:**

**DETAIL Z**

Höheneinstellung des Aushebeschutzes  
 Height adjustment of anti-jump device

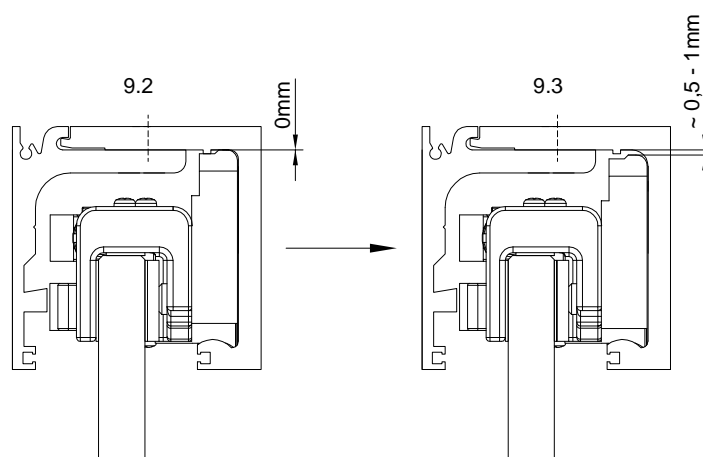
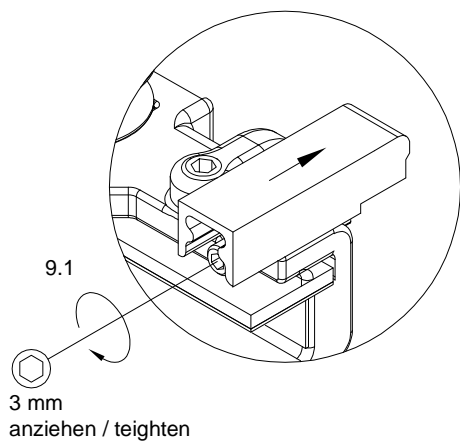

9.2 Hochdrehen bis Kontakt mit der Laufschiene besteht  
 9.3 Ca. 1/2 - 1 Umdrehung zurück drehen

9.2 Turn upwards until contact is achieved with track  
 9.3 Circa 1/2 - 1 turn backwards

**10. Positionierung der Laufwegbegrenzer:**  
**10. Positioning of the panel stops:**

Einzelür vor Wand laufend / Single door moved in ahead of the wall

$$L = M - 5$$

$$\dots = \dots - 5$$

$$L \quad M$$

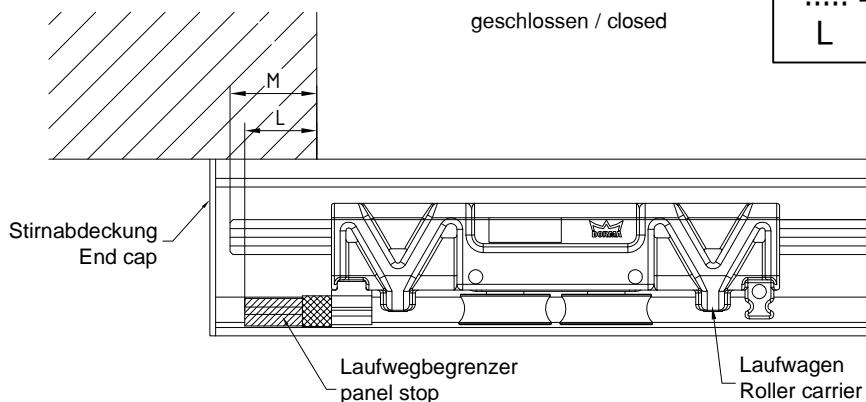

L = Position Stopper / position of stopper  
M = Glasüberstand / overlap of glass

Einzelür gegen Wand laufend / Single door moved against the wall

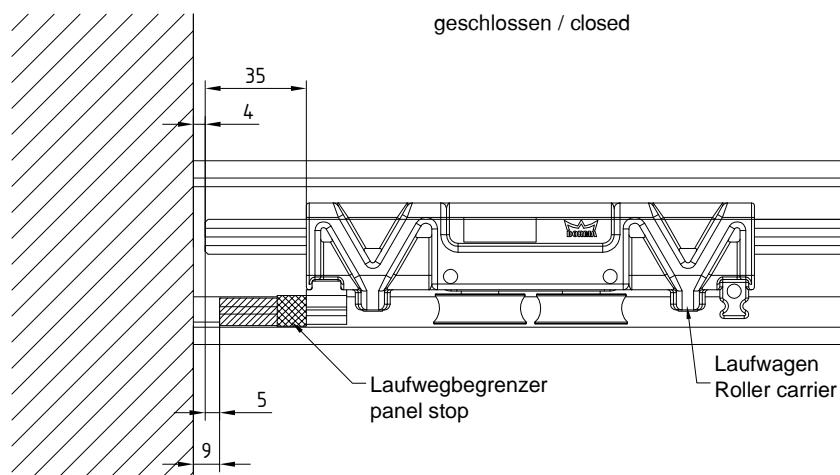

Doppeltür / double door

geschloss / closed

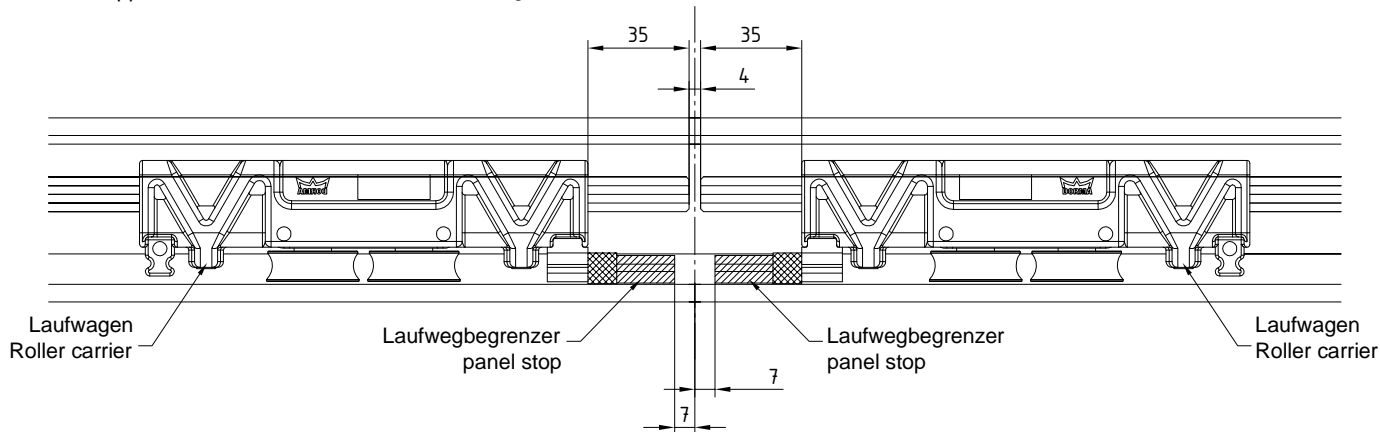

Die Position der Laufwegbegrenzer kann alternativ durch Versuch festgelegt werden!

The position of panel stop can be fixed by trying!

10. Positionierung der Laufwegbegrenzer:  
10. Positioning of the panel stops:

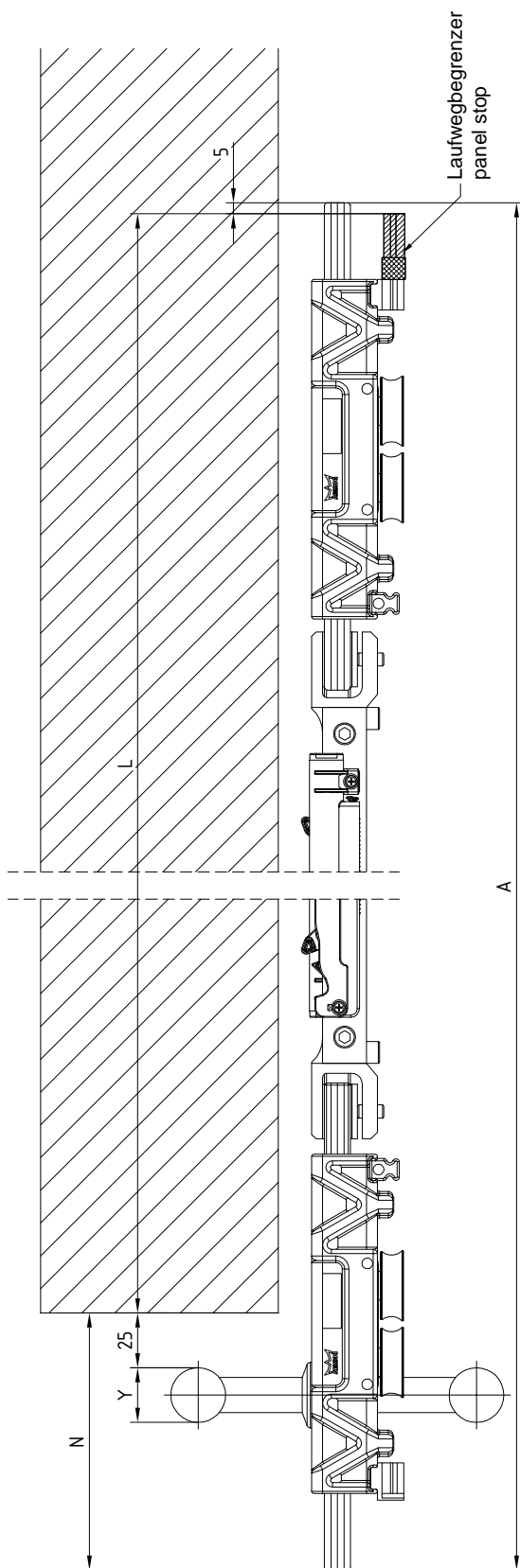

9.1 Laufwegbegrenzer nach den Berechnungen positionieren.  
9.1 Place the panel stops according to calculations.

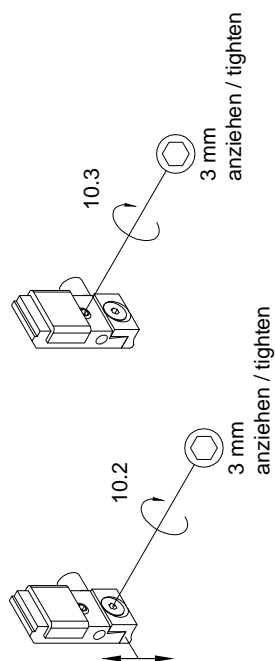

A = Glasbreite / glass width  
L = Position Stopper / position of stopper  
N = Abstand Glaskante zu Maueröffnung / distance of glass edge to wall opening  
X = Position Griff / position of handle  
Y = Griffbreite / handle width

$$N = X + (Y/2) + 25$$

$$\dots = \dots + (\dots/2) + 25$$

N   X   Y

$$L = A - N - 5$$

$$\dots = \dots - \dots - 5$$

L   A   N



**11. Positionierung der DORMOTION Start:**  
**11. Positioning of DORMOTION start:**

11.1 Tür öffnen und 1. DORMOTION Start nach der Berechnung positionieren.  
 Open the door and place the first DORMOTION start according to calculation.

11.2 Tür schließen und 2. DORMOTION Start nach der Berechnung positionieren.  
 Close the door and place the second DORMOTION start according to calculation.

**DORMOTION L:**  
**DORMOTION L:**

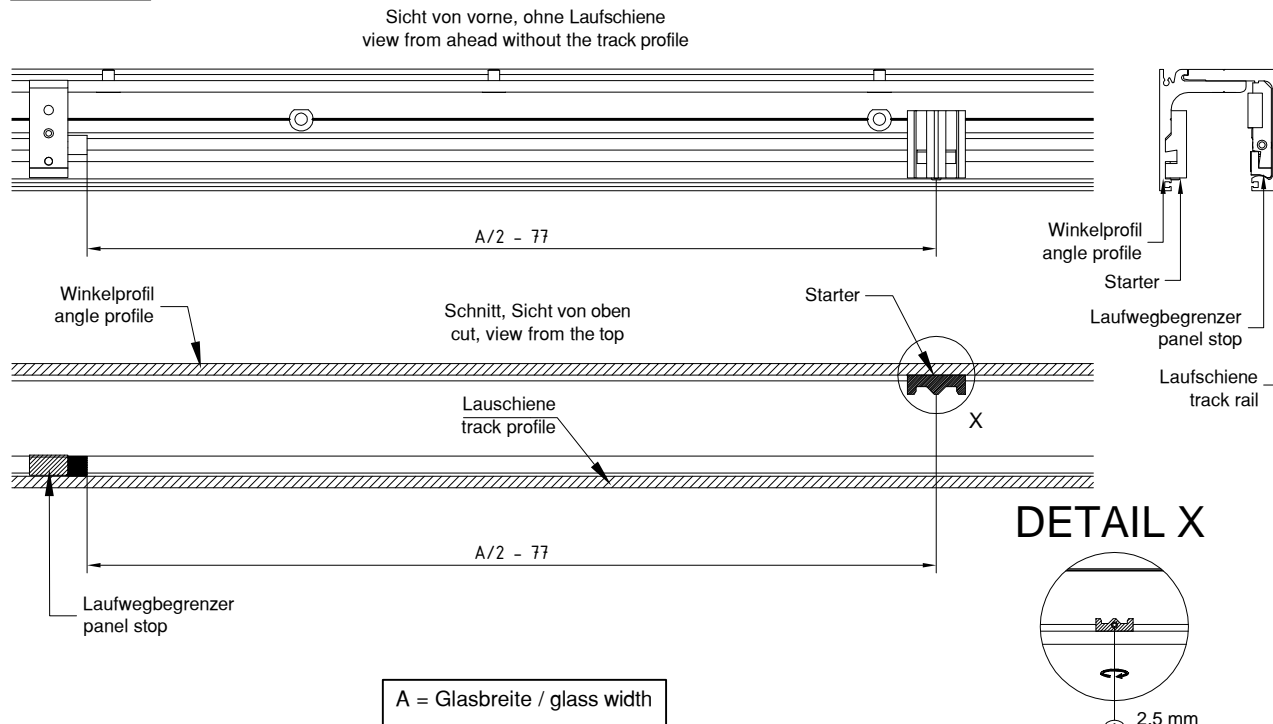

**DORMOTION XL:**  
**DORMOTION XL:**

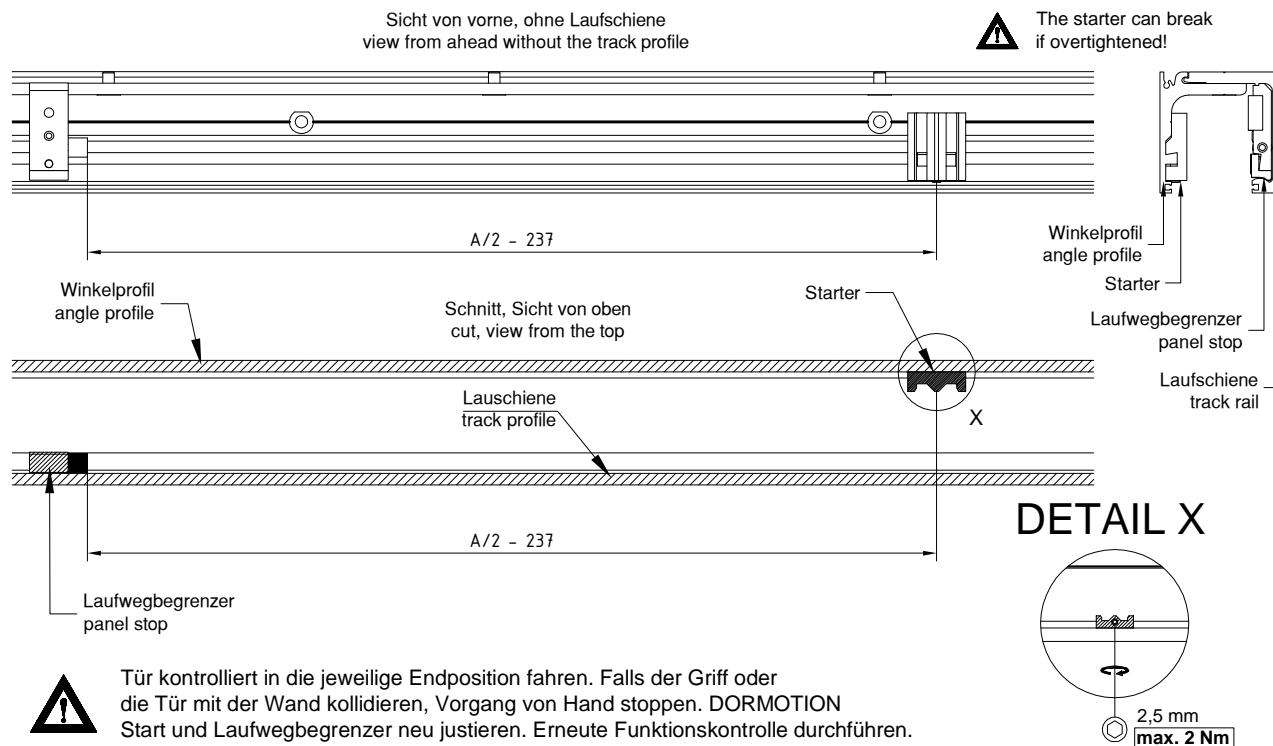

Tür kontrolliert in die jeweilige Endposition fahren. Falls der Griff oder die Tür mit der Wand kollidieren, Vorgang von Hand stoppen. DORMOTION Start und Laufwegbegrenzer neu justieren. Erneute Funktionskontrolle durchführen.



To avoid a collision or breakage of the glass panel, the door should be hand guided and under control in a fully opened and closed position. The respective end positions must be reached. In the case of a collision, either glass with wall or handle with wall, DORMOTION Start and panel stop should readjusted. After adjustment, repeat function control.



Starter kann bei zu starkem Anziehen brechen!



The starter can break if overtightened!



Starter kann bei zu starkem Anziehen brechen!



The starter can break if overtightened!

## 12. Glaskantenschutz: 12. Glass edge protection:



Vor dem Aufkleben Glaskanten im Bereich der Klebeflächen reinigen. Bitte nur Glasreiniger verwenden, die frei von Silikonen und Ölen sind (z.B. Aceton).



The glass edges are to be cleaned prior to affix. Only use glass cleaning products, free from silicones and oil (e.g. acetone).



Glaskantenschutz abziehen.  
Pull-off the glass edge protection.

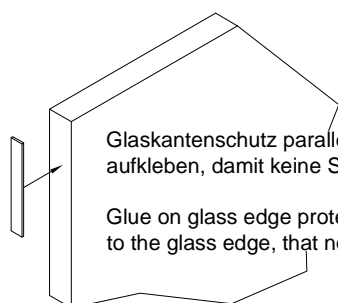

Glaskantenschutz parallel zur Glaskante mittig aufkleben, damit keine Schleifgeräusche entstehen!  
Glue on glass edge protection parallel and centred to the glass edge, that no rubbing noises occur!

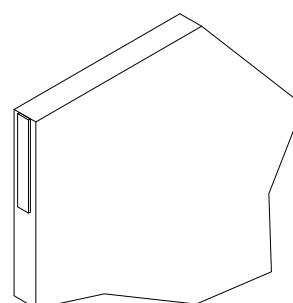

Glaskantenschutz vollständig (ohne Blasen) aufkleben, damit die volle Haftung erreicht wird!  
To attain the full adhesion, glue on glass edge protection completely ( without bubbles)!

### Einzeltür in Nische oder gegen Wand: Single door in a niche or against wall:

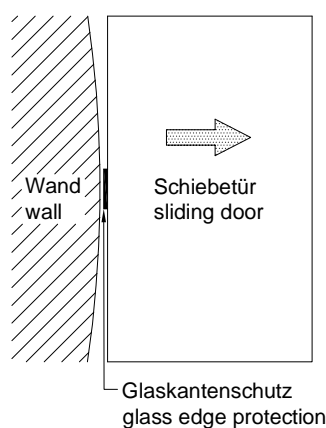

Glaskantenschutz im Kollisionsbereich zur Wand aufkleben.

Glue on glass edge protection onto glass, in area of possible collision with wal.

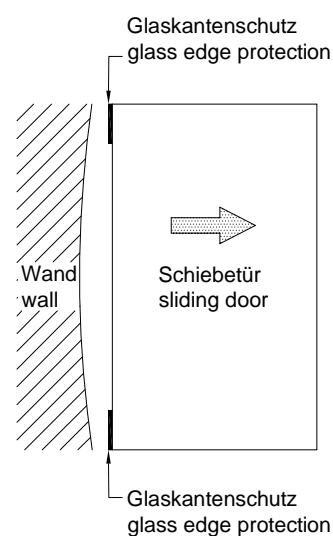

### Doppeltür: Double door:

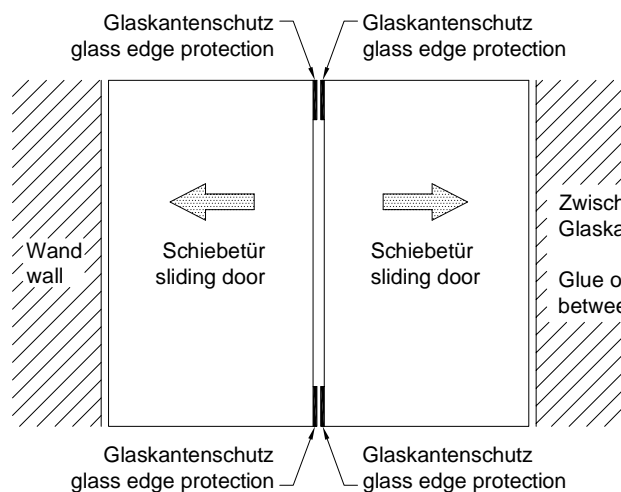

Zwischen den Flügeln den Glaskantenschutz aufkleben.

Glue on glass edge protection between the panels.

**13. Montage der Sichtschutzbürste (optional):**  
**13. Installation of brush profile (optional):**

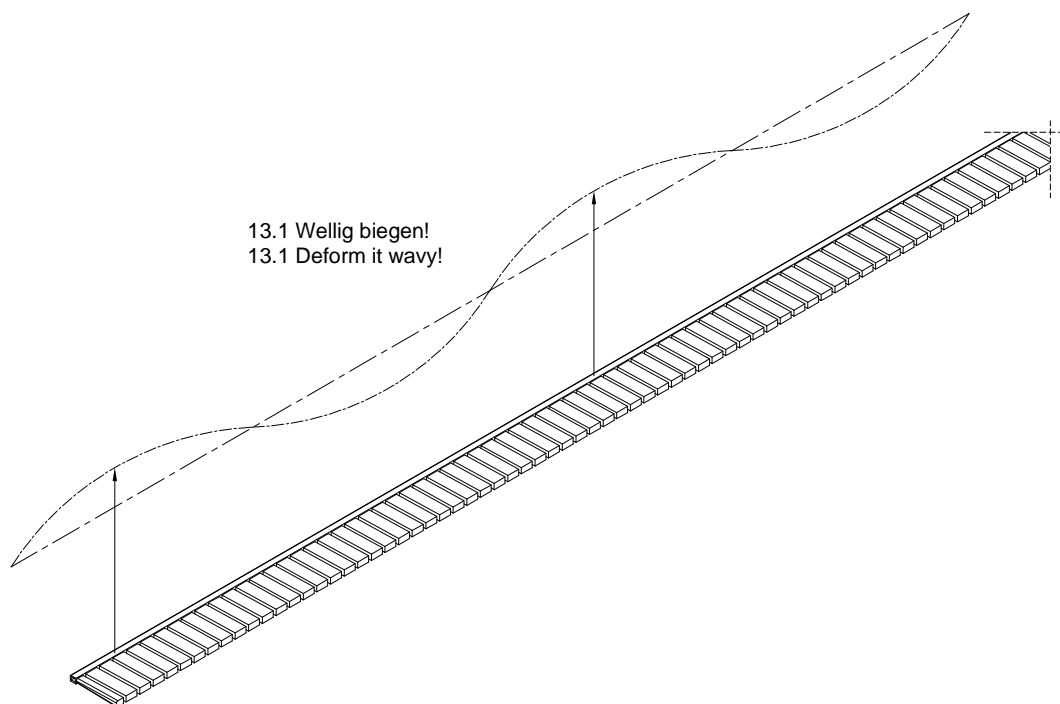

Vor der Profil-Montage: Seitlich einschieben.  
 Before profile installation: insert sidwise.

Nach der Profil-Montage: Von vorne einfedeln.  
 After profile installation: insert from ahead.

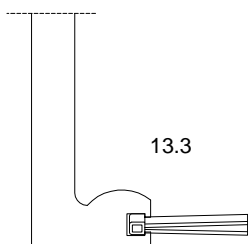
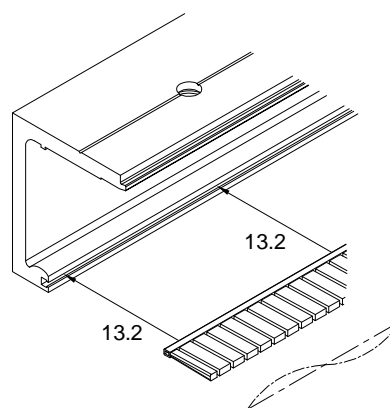
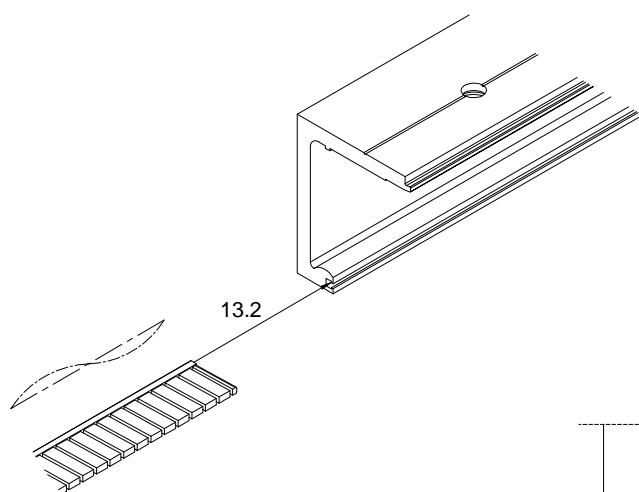

#### 14. Montage der Stirnabdeckungen:

#### 14. Installation of end caps:

14.1 Stirnabdeckungen an beiden  
Enden der Laufschiene anbringen.

14.1 Fixing of end caps on both sides of track profile.

